

FEATURES

- All-silicon time delay
- 5 taps equally spaced
- Delays are stable and precise
- Both leading and trailing edge accuracy
- Delay tolerance $\pm 5\%$ or ± 2 ns, whichever is greater
- Low-power CMOS
- TTL/CMOS-compatible
- Vapor phase, IR and wave solderable
- Custom delays available
- Fast turn prototypes
- Extended temperature range available (DS1000-IND)

PIN ASSIGNMENT

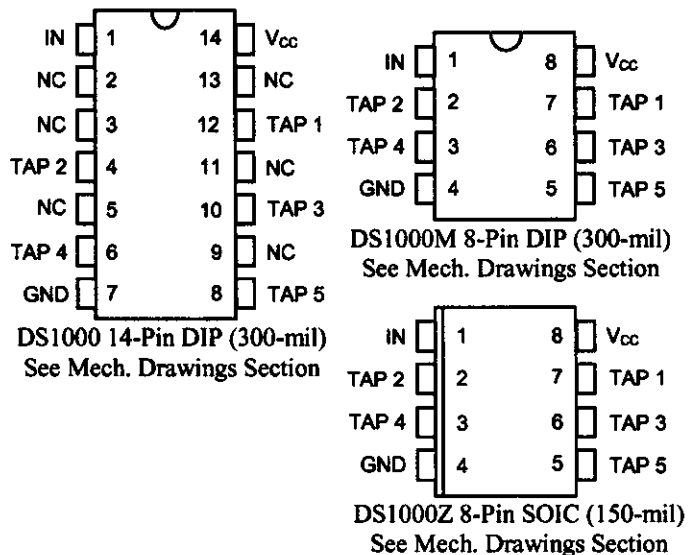

PIN DESCRIPTION

TAP 1-TAP 5	- TAP Output Number
V _{CC}	- +5 Volts
GND	- Ground
NC	- No Connection
IN	- Input

DESCRIPTION

The DS1000 series delay lines have five equally spaced taps providing delays from 4 ns to 500 ns. These devices are offered in a standard 14-pin DIP that is pin-compatible with hybrid delay lines. Alternatively, 8-pin DIPs and surface mount packages are available to save PC board area. Low cost and superior reliability over hybrid technology is achieved by the combination of a 100% silicon delay line and industry standard DIP and SOIC packaging. In order to maintain complete pin compatibility, DIP packages are available with hybrid lead configurations. The DS1000 series delay lines provide a nominal accuracy of $\pm 5\%$ or ± 2 ns, whichever is greater. The DS1000 5-Tap Silicon Delay Line reproduces the input logic state at the output after a fixed delay as specified by the extension of the part number after the dash. The DS1000 is designed to reproduce both leading and trailing edges with equal precision. Each tap is capable of driving up to ten 74LS loads. Dallas Semiconductor can customize standard products to meet special needs. For special requests and rapid delivery, call 972-371-4348.

LOGIC DIAGRAM Figure 1

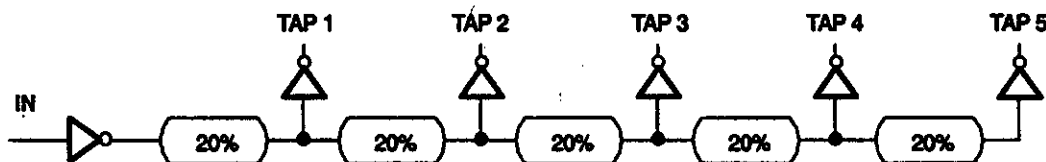

DS1000

PART NUMBER DELAY TABLE (all values in ns) Table 1

PART # DS1000-	TAP 1			TAP 2			TAP 3			TAP 4			TAP 5		
	Nom	TOLERANCE		Nom	TOLERANCE		Nom	TOLERANCE		Nom	TOLERANCE		Nom	TOLERANCE	
		Init	Temp		Init	Temp		Init	Temp		Init	Temp		Init	Temp
-20	4	2	1	8	2	1	12	2	1	16	2	1	20	2	1
-25	5	2	1	10	2	1	15	2	1	20	2	1	25	2	1
-30	6	2	1	12	2	1	18	2	1	24	2	1	30	2	1
-35	7	2	1	14	2	1	21	2	1	28	2	1	35	2	1.1
-40	8	2	1	16	2	1	24	2	1	32	2	1	40	2	1.2
-45	9	2	1	18	2	1	27	2	1	36	2	1.1	45	2.3	1.4
-50	10	2	1	20	2	1	30	2	1	40	2	1.2	50	2.5	1.5
-60	12	2	1	24	2	1	36	2	1.1	48	2.4	1.5	60	3	1.8
-75	15	2	1	30	2	1	45	2.3	1.4	60	3	1.8	75	3.8	2.3
-100	20	2	1	40	2	1.2	60	3	1.8	80	4	2.4	100	5	3
-125	25	2	1	50	2.5	1.5	75	3.8	2.3	100	5	3	125	6.3	3.8
-150	30	2	1	60	3	1.8	90	4.5	2.7	120	6	3.6	150	7.5	4.5
-175	35	2	1.1	70	3.5	2.1	105	5.3	3.2	140	7	4.2	175	8.8	5.3
-200	40	2	1.2	80	4	2.4	120	6	3.6	160	8	4.8	200	10	6
-250	50	2.5	1.5	100	5	3	150	7.5	4.5	200	10	6	250	12.5	7.5
-500	100	5	3	200	10	6	300	15	9	400	20	12	500	25	15

DC ELECTRICAL CHARACTERISTICS

(0°C to 70°C; $V_{CC} = 5.0V \pm 5\%$)

PARAMETER	SYM	TEST CONDITION	MIN	TYP	MAX	UNITS	NOTES
Supply Voltage	V_{CC}		4.75	5.00	5.25	V	6
High Level Input Voltage	V_{IH}		2.2		$V_{CC} + 0.5$	V	6
Low Level Input Voltage	V_{IL}		-0.5		0.8	V	6
Input Leakage Current	I_I	$0.0V \leq V_I \leq V_{CC}$	-1.0		1.0	μA	
Active Current	I_{CC}	$V_{CC} = \text{Max};$ $\text{Period} = \text{Min.}$		35	75	mA	7, 9
High Level Output Current	I_{OH}	$V_{CC} = \text{Min.}$ $V_{OH} = 4$			-1	mA	
Low Level Output Current	I_{OL}	$V_{CC} = \text{Min.}$ $V_{OL} = 0.5$	12			mA	

AC ELECTRICAL CHARACTERISTICS

 $(T_A = 25^\circ C; V_{CC} = 5V \pm 5\%)$

PARAMETER	SYMBOL	MIN	TYP	MAX	UNITS	NOTES
Input Pulse Width	t_{WI}	40% of Tap 5 t_{PLH}			ns	8
Input to Tap Delay (leading edge)	t_{PLH}		Table 1		ns	1, 2, 3, 4, 5, 10
Input to Tap Delay (trailing edge)	t_{PHL}		Table 1		ns	1, 2, 3, 4, 5, 10
Power-up Time	t_{PU}			100	ms	
Input Period	Period	4 (t_{WI})			ns	8

CAPACITANCE $(T_A = 25^\circ\text{C})$

PARAMETER	SYMBOL	MIN	TYP	MAX	UNITS	NOTES
Input Capacitance	C_{IN}		5	10	pF	

NOTES:

1. Initial tolerances are \pm with respect to the nominal value at 25°C and 5V .
2. Temperature tolerance is \pm with respect to the initial delay value over a range of 0°C to 70°C .
3. The delay will also vary with supply voltage, typically by less than 4% over the range 4.75 to 5.25V .
4. All tap delays tend to vary uni-directionally with temperature or voltage changes. For example, if TAP 1 slows down, all other taps also slow down; TAP3 can never be faster than TAP2.
5. Intermediate delay values and packaging variations are available on a custom basis. For further information, call 972-371-4348.
6. All voltages are referenced to ground.
7. Measured with outputs open.
8. Pulse width and period specifications may be exceeded; however, accuracy may be impaired depending on application (decoupling, layout, etc.). The device will remain functional with pulse widths down to 20% of Tap 5 delay, and input periods as short as $2(t_{wI})$.
9. I_{CC} is a function of frequency and TAP 5 delay. Only a -25 operating with a 40-ns period and $V_{CC} = 5.25\text{V}$ will have an $I_{CC} = 75\text{ mA}$. For example a -100 will never exceed 30 mA , etc.
10. See "Test Conditions" section at the end of this data sheet.

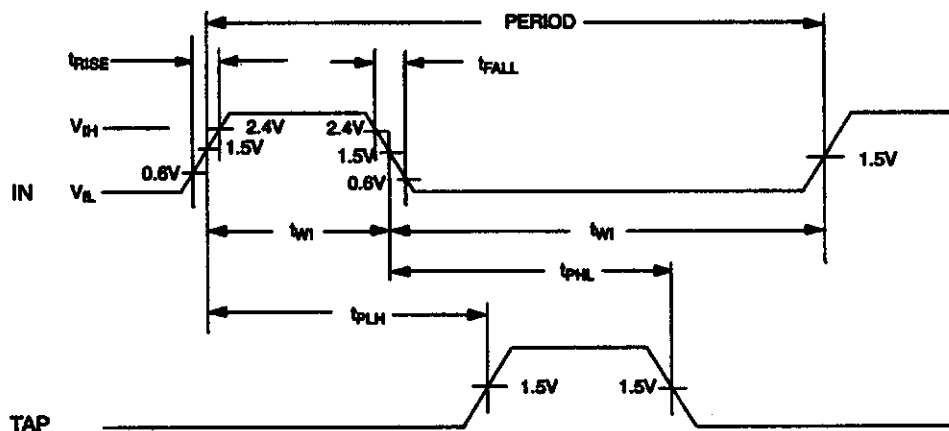
TIMING DIAGRAM: SILICON DELAY LINE Figure 2

TEST CIRCUIT Figure 3

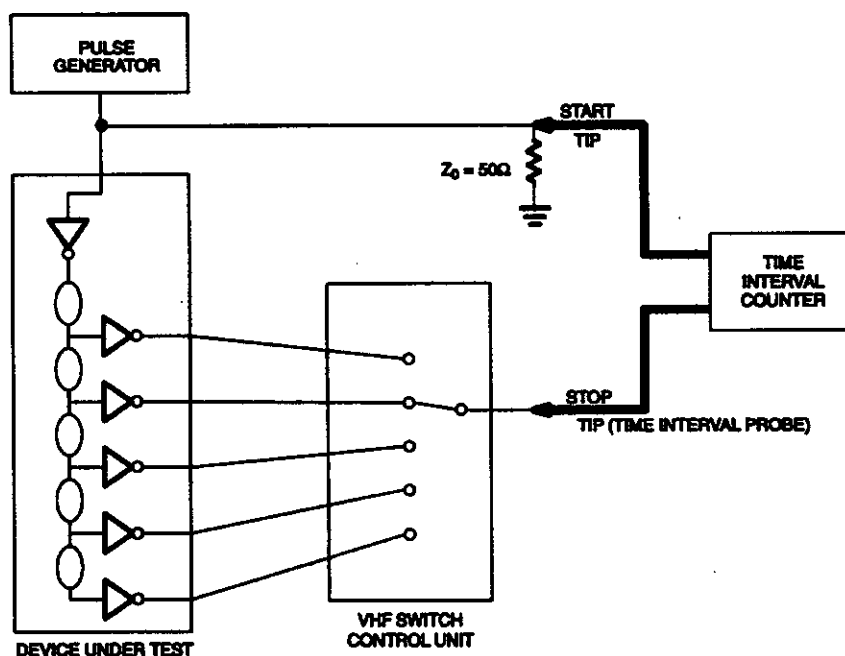

TERMINOLOGY

Period: The time elapsed between the leading edge of the first pulse and the leading edge of the following pulse.

t_{WI} (Pulse Width): The elapsed time on the pulse between the 1.5V point on the leading edge and the 1.5V point on the trailing edge or the 1.5V point on the trailing edge and the 1.5V point on the leading edge.

t_{RISE} (Input Rise Time): The elapsed time between the 20% and the 80% point on the leading edge of the input pulse.

t_{FALL} (Input Fall Time): The elapsed time between the 80% and the 20% point on the trailing edge of the input pulse.

t_{PLH} (Time Delay, Rising): The elapsed time between the 1.5V point on the leading edge of the input pulse and the 1.5V point on the leading edge of any tap output pulse.

t_{PHL} (Time Delay, Falling): The elapsed time between the 1.5V point on the trailing edge of the input pulse and the 1.5V point on the trailing edge of any tap output pulse.

TEST SETUP DESCRIPTION

Figure 3 illustrates the hardware configuration used for measuring the timing parameters on the DS1000. The input waveform is produced by a precision pulse generator under software control. Time delays are measured by a time interval counter (20 ps resolution) connected between the input and each tap. Each tap is selected and connected to the counter by a VHF switch control unit. All measurements are fully automated, with each instrument controlled by a central computer over an IEEE 488 bus.

TEST CONDITIONS

INPUT:

Ambient Temperature:	$25^{\circ}\text{C} \pm 3^{\circ}\text{C}$
Supply Voltage (V_{CC}):	$5.0\text{V} \pm 0.1\text{V}$
Input Pulse:	High = $3.0\text{V} \pm 0.1\text{V}$ Low = $0.0\text{V} \pm 0.1\text{V}$
Source Impedance:	50 ohm Max.
Rise and Fall Time:	3.0 ns Max. (measured between 0.6V and 2.4V)
Pulse Width:	500 ns (1 μs for -500)
Period:	1 μs (2 μs for -500)

OUTPUT:

Each output is loaded with the equivalent of one 74F04 input gate. Delay is measured at the 1.5V level on the rising and falling edge.

NOTE:

Above conditions are for test only and do not restrict the operation of the device under other data sheet conditions.